

User information

AquaControl + *Fill level measuring device and drinking water supply*

Item no.: 351021

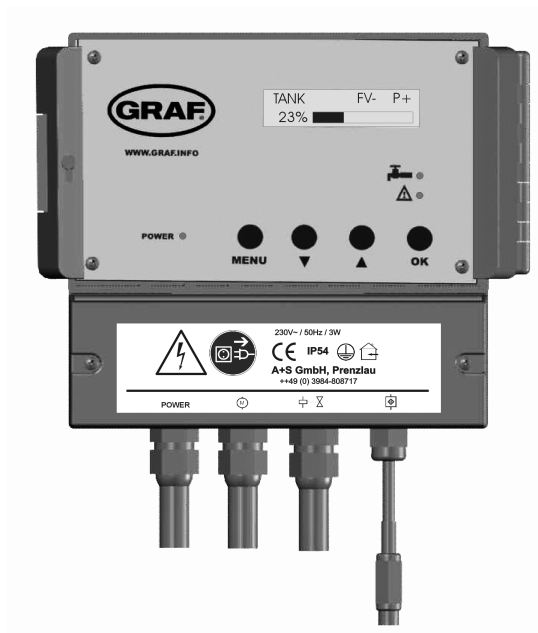

Otto Graf GmbH
Kunststoffzeugnisse

Carl-Zeiss-Str. 2-6
D-79 331 Teningen

Tel. : 07641-5890
Fax: 07641-58950

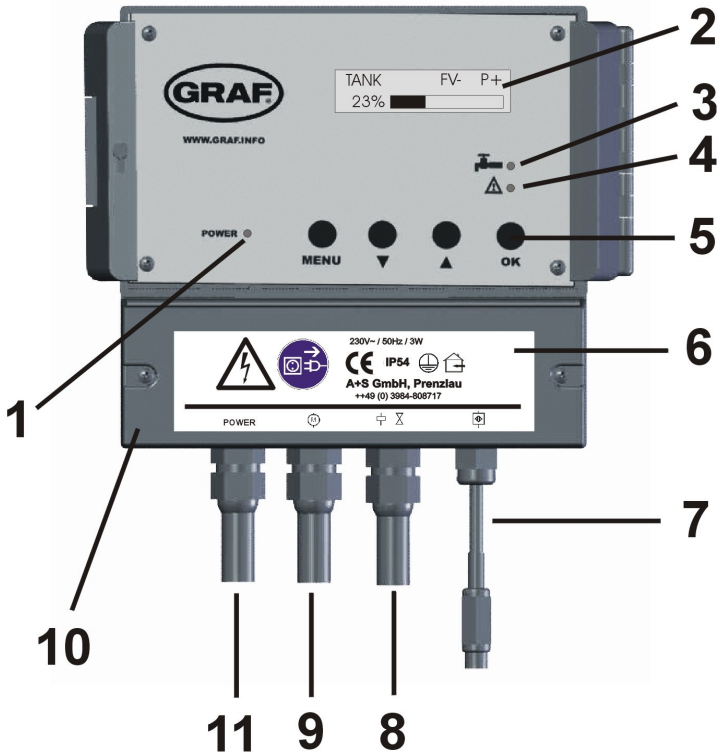

Figure 1: View of equipment

- 1: LED for power supply display
- 2: Display
- 3: LED for drinking water operation
- 4: LED for faults and malfunction
- 5: Operating buttons
- 6: Lower cover of the System Control
- 7: Main connection cable with coupling for data lead
- 8: Valve connection with power coupling
- 9: Pump connection with power coupling
- 10: The mains circuit breaker of the system controls are under this cover.
- 11: Mains power supply cable

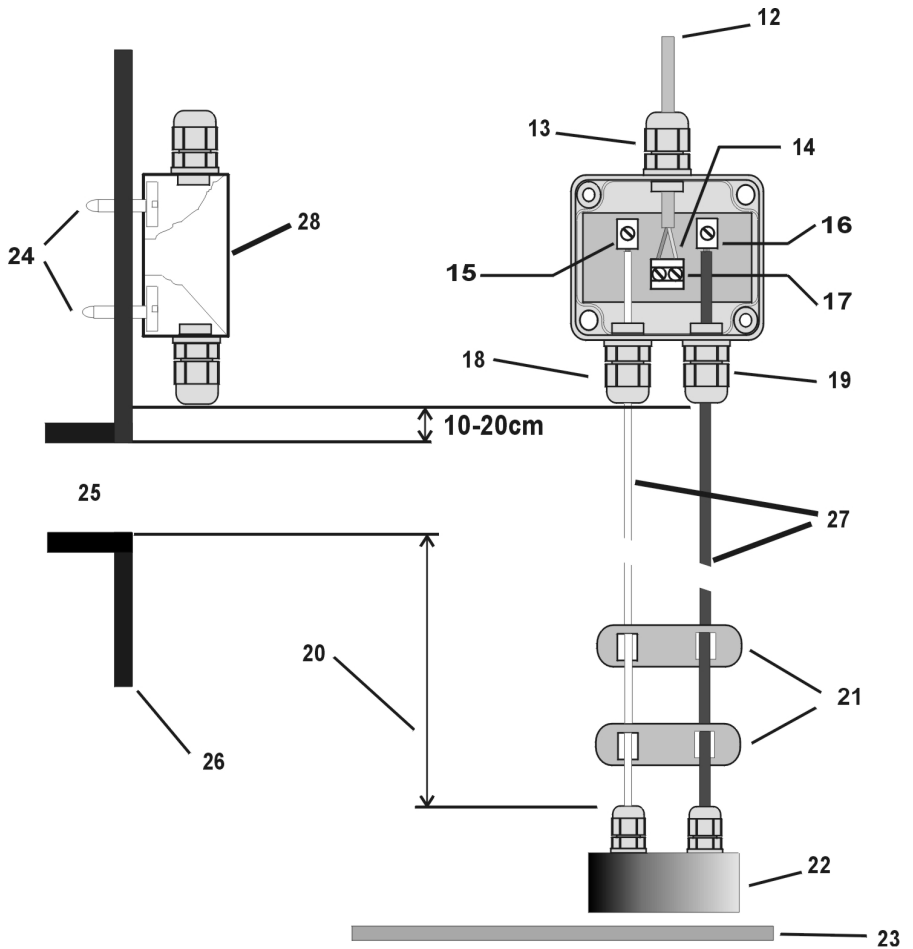

Figure 2: Sensor assembly

- 12: Data cable
- 13: screw cap 3
- 14: Connection of the data cable is reverse protected.
- 15: connect white cable here
- 16: connect red cable here
- 17: data cable terminal
- 18: screw cap 2

- 19: screw cap 1
- 20: active measuring length
- 21: When assembling be sure, that the cable spacers are equally distributed over the cable length.
- 22: Stainless steel probe
- 23: Tank floor
- 24: Screws must be blunted ! (danger of injury)
- 25: overflow
- 26: Tank side in dome
- 27: Sensor
- 28: Sensor control box (measurement pick-up)

Important notes on safety:

Please, read and follow safety instructions carefully before assembly or using the device!

During installation and when working with 230 V ~ mains supply the VDE regulations must be followed. Equipment using a 230 V ~ supply may only be installed and commissioned by a qualified tradesman. The assembly place must allow all possible safety precautions when laying the attached cables.

Power supply cables and data cables may not be damaged or squeezed for any reasons. Plan the assembly place so that you can reach the mains plug easily and unplug it from the electrical outlet in dangerous situations.

Choose the assembly place so that children cannot play or be near to the device and at its connections without supervision.

Before opening the device disconnect it from the mains supply (unplug) otherwise there is a serious danger of an electrical shock.

Fuses may only be replaced with standard-compliant parts with the same nominal value.

All liability is excluded for damages which result from non-compliance of these instructions or from an improper handling of the device. At chosen intervals in this hand book we will give directions for safety precautions. These safety precautions have been specially marked:



STOP Before opening the equipment
pull the plug out from the mains socket !

1. Description

The **AquaControl+** is an electronic water management control system. It has been developed especially for rain water usage systems. It can be used with a wide variety of tank systems.

Tanks made from metal or steel reinforced cement may only be used when the following conditions have been correctly followed.

Metal tanks lead to faulty readings. Helpful is to assemble the device so that the sensor is as far as possible from the metal sides so for example, in the centre of a cylindrical tank. The system controls offer an easy to use guide for the switch programming. Using an LCD display the fill measurement is shown in 1 % stages (in relation to the height of the tank).The sensor operates with a 12 volt supply. All programmed **values such as the tank height are retained after disconnection of the power supply or after a power-cut.**

Performance features:

- Fill level measurement readout in 1% steps and with an additional bar type indicator
- In 1% steps freely variable choice of the switching points for the drinking water refill
- Automatic flushing of the system (choice of intervals in day and time are possible)
- Dialog oriented user guidance (choice of language)
- Equipment indication using 3 additional LED
- Supervision of the measurement pick-up and the sensor
- Error indication in simple text

Technical data:

Control electronics

Operating current	:230VAC
Fused	:T50mA
Power consumption	:3VA
Tank height	:3m (optional 6m)
Measurements [mm]	:155x165x90

Measurement sensors

Measurement voltage	:12DC
Measuring frequency	:(0,2-20)kHz
Data cable length	:20m
Measurements [mm]	:90x80x50

Pump connection

Operating voltage :230V AC
Pump capacity :max. 1200VA

Valve connection

Operating voltage :230V AC
Valve effective performance : max. 1A

Note:

*Only the control electronics in the device are protected by the fuse. Valves and pump connections are **not** protected. These are protected only by the mains supply via the mains fuse.*

The yellow LED indicating “Drinking water operation” [3] is lit as soon as the valve switches over to the mains supply. The user is made aware that the system now uses water from the mains supply. The red LED for “Faults and malfunctions” [4] is lit as soon as the system identifies a fault. The display will then show a warning that describes the cause of the fault in plain text.

2. Assembly

2.1 Control system

The mains plug of the device serves as an on / off switch.



STOP Before opening the equipment
pull the plug out from the mains socket !

- Loosen the fastening screws of the lower cover [6] and remove the cover
- Mark out drilling points and drill according to sketch
- Fasten the device with the enclosed installation material (rawlplugs and screws)

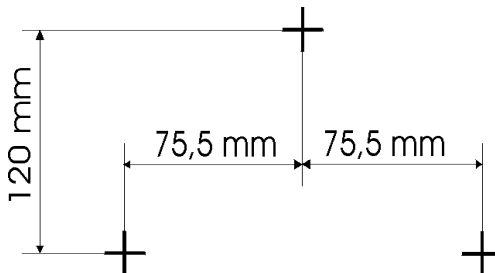

Figure 3: Drilling outline for housing outline

2.2 Connection sensors and data cable:

The sensor electronics comprise of a stainless steel probe [22] with a red and a white connecting cable [27] and the sensor measurement pick-up [28].

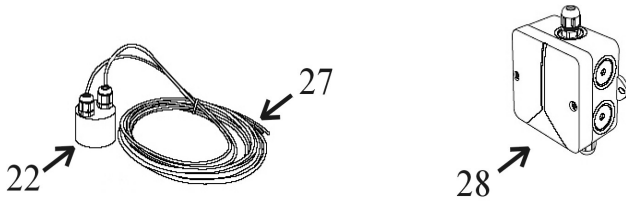

Figure 4: Sensor technology

1. Now the sensor measurement pick-up [28] (cover removed) should be installed on the tank wall (preferably in the man hole shaft of the Graf synthetic tank). The location of the mounted sensor pick-up should be between 10 and 15 cm above the overflow [25]. The enclosed screws should be used to secure the device. After fully tightening the screws, the points that are showing themselves on the outside of the tank must be blunted to avoid injury [24].
2. Measure the height from the bottom of the tank [23] to the end of the terminals [15] and [16] on the measurement pick-up [28].
3. Shorten the connection cable to suit the measured height.
4. After shortening the cable, the distance between the cable fastening spacers [21] should be set equally along the entire length. The cable fastening spacers prevent the red and white cables of the sensor from crossing over and thereby causing a slight distortion of the measurement readings. If for any reason the cable fastening spacers cannot be mounted, an additional distortion of the measurement reading of approximately 1% may result.
5. Connect the sensor cable to the sensor as described in the following instructions: Remove between 5-7 mm of the insulation from both of the cables. Next, pass the red cable through the screw mounting 1 [19] and tighten this lightly, then connect the red cable to the terminal [16]. The free white cable is now passed through the screw mounting 2 [18] and tightened lightly, then connect the white cable to the terminal [15].

6. Now pass the end of the data cable that has no plug connector [12] through the screw mounting 3 [13]. Lightly tighten the screw mounting and connect the cable wire cores of the data cable [12] to the double terminal [14]. The connection of the data cable is reverse polarity protected. **Attention! The screws should be tightened with care to ensure that they are not damaged through over tightening.**

7. Now recheck that all the screwed items and the sensor components have been fitted correctly. Replace the cover of the measurement pick-up and secure this with the appropriate fastening screws.

8. The installation of the data cable [12] to the system control must be according to good professional practice to constitute a correct completion of the sensor technology: A protective cable conduit must be used. (The data cable is not suitable for installing directly in the earth). The end of the data cable that is still unconnected is fitted with a plug connector. This is to be plugged into the appropriate socket [7] of the system control. Diagram 2 on page 3 makes clear the interrelation:

Note:

The red and the white cable going down to the probe should be straight and smooth to be drawn taught by the weight of the stainless steel probe. The stainless steel probe must hang just above the tank floor. When setting the spacers please be sure to distribute them equally over the complete length as shown in Figure 2.

2.3. Electrical wiring diagram

The AquaControl+ offers the rain water system a dry run protection for the pump or the house water system. So that the dry run protection will function properly the rain water system must be wired according to the following diagram.

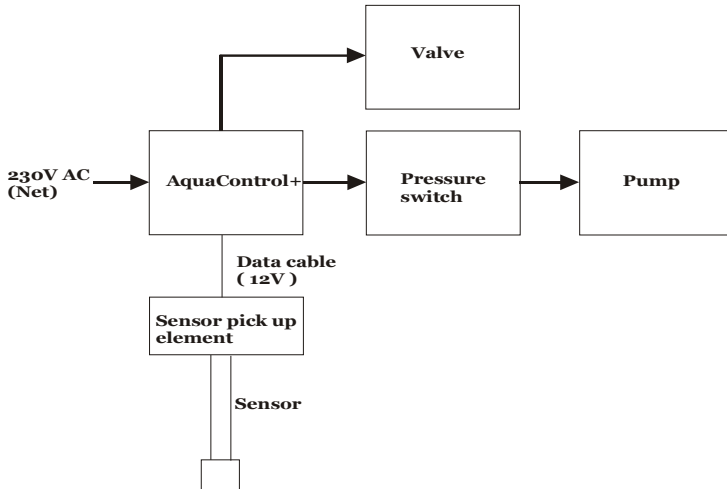

Figure 5: electrical wiring diagram

Note:

Should the existing pump or house water system already have a dry run protection it may be appropriate and is possible to order the AquaControl+ without a dry run protection.

2.4 Connection of the solenoid valve

Connect the plug of the solenoid valve with the centre coupling [8] of the control electronics (see figure 1).

3.Commissioning

Before the putting the equipment into operation check and be sure that all electrical connections are correctly insulated and all covers are properly closed.

Now open the transparent cover of the system controls. Plug the equipment into the mains socket (this socket must be exclusively for the equipment and be on its own fuse). The system then runs a system check through automatically.

For the duration of the system check (approx. 10 seconds) the following signal will be displayed in the window:

Figure 6: Display during the equipment check

The equipment type is shown on the first line and the software check in progress is shown in the second line.
If after the initial installation check all is correct, the LCD indicator will display the fill level (in %).

The figure 7 shows the LCD-display in the operation mode. The display shows the filling level and the operating modes as abbreviations: "FV" and "P". These abbreviations correspond as follows:

- FV+ : filter valve opened
- FV- : filter valve closed
- P+ : (pump on) house waterworks in operation
- P- : (pump off) no water currently being withdrawn

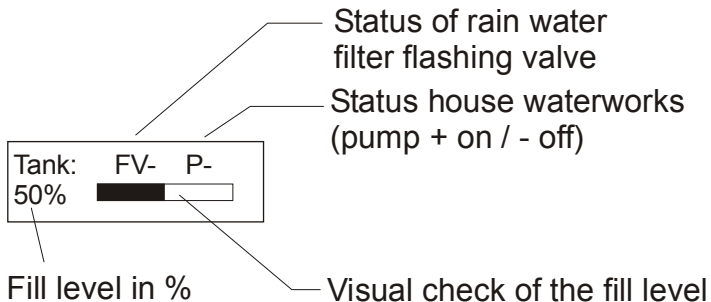

Figure 7: Display in the operation mode

4. Set up of the system control:

After putting into operation, the system control must be adjusted and programmed according to the conditions and requirements of the individual users system. The required settings are easily programmed. There are four buttons for this purpose. All necessary programming data entries follow a menu displayed by the LCD. For the set up follow all the points listed in table 1 in the sequence as shown. Should any error in the sequence occur then it is necessary to begin the set up again from the beginning starting with the tank height. Begin the programming of the settings by pressing the button marked "MENU".

With the buttons "+" or "-" the menu may be scrolled backwards and forwards.

With the respective menu point shown the values may be altered. For this the button "ENTER" must be used. The "?" displayed in the LCD will now change to a ">" graphic character. With the "+" or "-" the desired value may now be entered according to individual requirements. When the desired value has been entered this must be confirmed by pressing the "ENTER" button. The value is only then taken over and stored in the programming of the unit.

Through pressing the "MENU" button again the display changes back to the operation mode.

It is possible to reset the unit to the factory setting standard values at any time.

The resetting can only be carried out in the operation mode (Display see Figure 7): To do this press the "ENTER" button and hold it pressed. Now simultaneously in addition press the "MENU" button. After a short wait the following display will be shown:



Figure 8: Message reset to standard factory settings

As soon as this message is displayed the buttons may be released

The menu structure integrated in the system control is introduced to familiarise the user in diagram 9. To bring up the menu, press and hold the „MENU“ button for longer than 5 seconds. All outlets are inactive when the menu level has been activated. The operation of the device is suspended. The system control switches automatically back to the operating mode when no entries have been received for approximately 30 seconds.

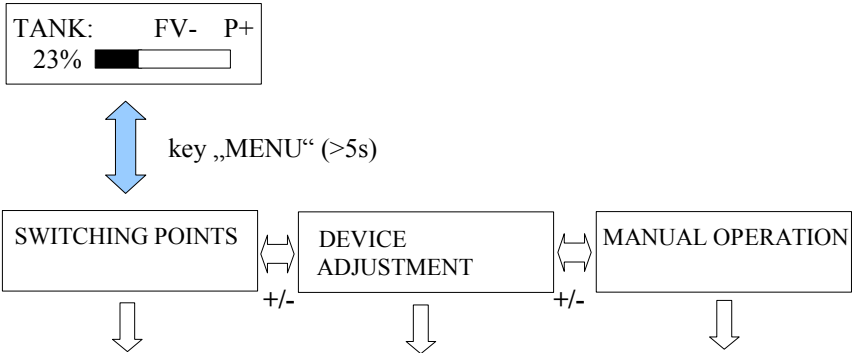
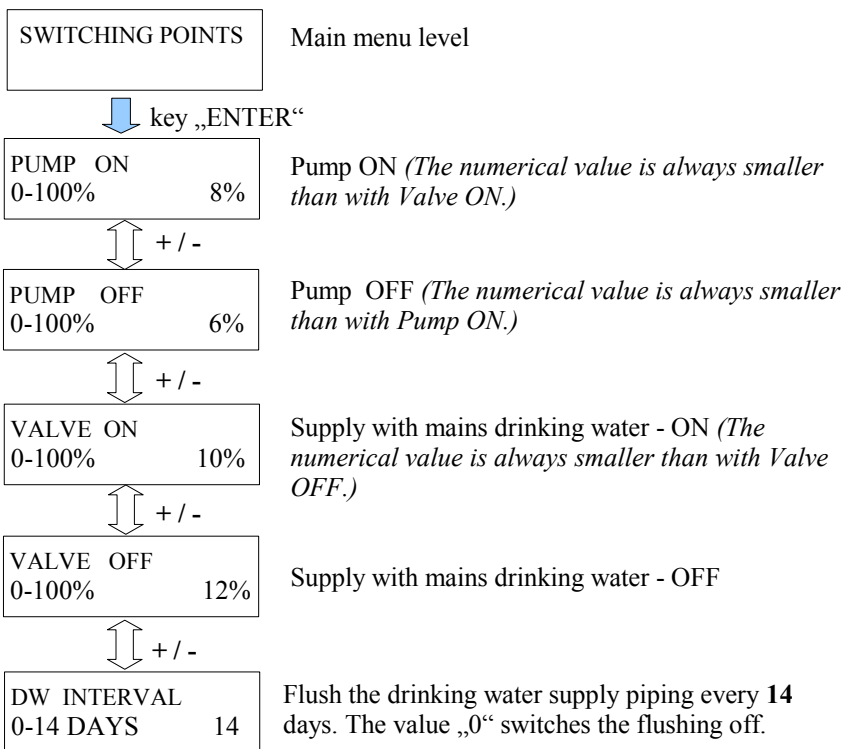

Figure 9: Main menu level

Press the “ENTER” button to arrive at each of the listed sub-menu functions. Through pressing the “MENU” button again the display changes back to the operation mode.



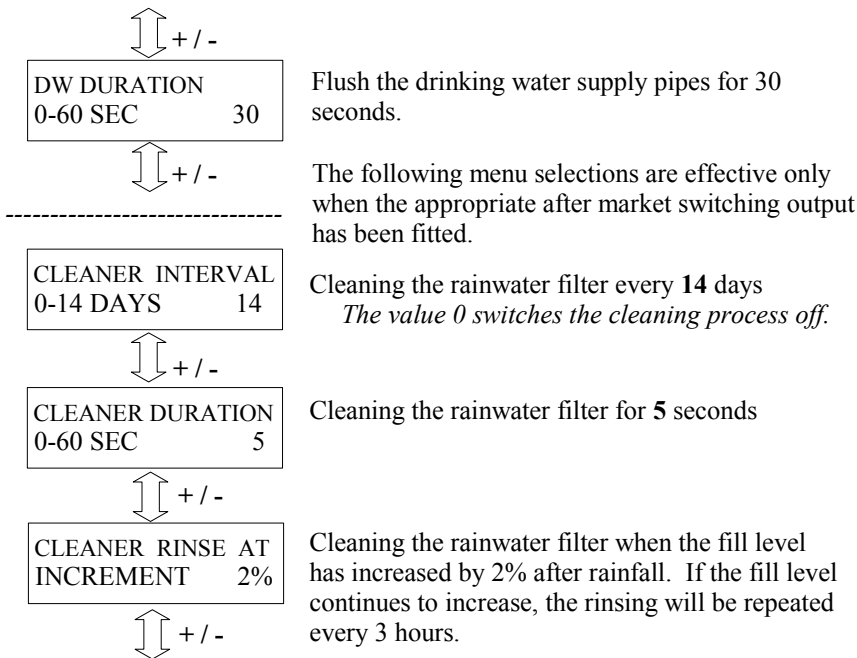

Figure 10: Sub-menu “Switching points”

Press the „ENTER“ button to alter the respective switching points. The value to be altered will begin to blink. The value may then be adjusted by using the „+“ and the „-“ buttons. Press the “ENTER” button again when the displayed value should be accepted.

The following is an introduction to the general device settings:

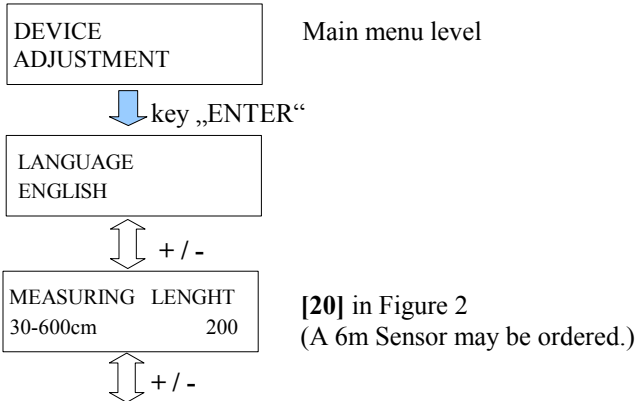

Figure 11: Sub-menu “General device description”

The last part of the operation level covers the manual functions:

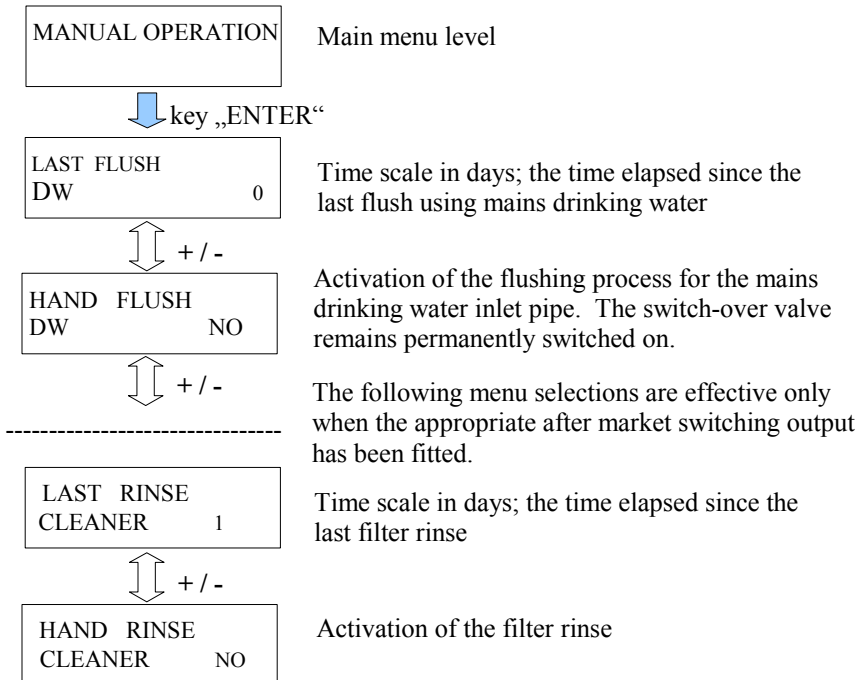

Figure 12: Sub-menu “Manual functions”

5. Error messages and fault correction:

The operation of the system control is to be checked at regular intervals (at the latest every 4 weeks).

The read out reports always represent only probabilities; e.g. no clear localization by the device is possible for overlying faults.

Please also take note that the system control device cannot identify any malfunction of the house water system. (No malfunction signal is supplied by the house water system to the system control device).

If faults are recognized by the sensors the system control cannot continue to work **independently**.

The particular faults are shown on the plain text in the display:

ERROR
SENSOR

The reason for this error is that the white sensor cable has been damaged.

ERROR
DL SHORT CIRCUIT

Error possibilities:

- The data cable of the measurement pick-up is not connected to the data cable terminal [14] but has been connected to the sensor terminal [15/16]
- Cinch plug or the cinch connector has a short circuit
- Wires of the data cable have been damaged

ERROR
SENSOR CONTROL

The measurement sensor delivers no signal and must be replaced.

ERROR
SENSOR SYSTEM

For further diagnosis, remove the stainless steel weight [22] out of the water. If the error indication has now stopped, then the sensor itself was the cause of the fault. If the error indication should continue, this implies that the measurement pick-up is defect.

ERROR
NO SIGNAL

The communication between the system control to the measurement pick-up is interrupted.

ERROR
MEMORY

First try re-setting the system control to the factory default settings . If the error message continues to be displayed then it is necessary to contact your service partner.

Note: *After re-setting to the factory default settings all the newly programmed setting values will have been overwritten and must be re-programmed!*

Figure 13: Error messages

If the device shows no function at all then check whether the main electrical supply provides current and also check the house fuses.



STOP Before opening the equipment
pull the plug out from the mains socket !

If the electrical outlet is under current, then unplug the mains plug from the system control. Without connection to current open the lower cover of the system control (see Figure 1) and check the equipments mains fuse.

If your efforts are unsuccessful, please consult the manufacturer by **E-Mail**:

A+S Aktuatorik und Sensorik GmbH
Franz – Wienholz- Str. 40
D-17 291 Prenzlau

Tel. : +49 (0) 3984 – 80 87 17
Internet : www.aktuatorikundsensork.com
E-Mail : info@AS-Prenzlau.de

Please have the serial number of the device ready when you contact us! The serial No. is to be found on the Serial number plate on the lower cover of the system control.

6. Upgrade options:

The SILENTIO control device **can** also be equipped with a number of additional special functions.

1. Option error message:

An error message can be sent, e.g. regarding the failure of a sensor can be delivered by a potential-free contact (changeover contact element; max. 230 VAC, 1 A).

2. Option 0-10V: output point

There follows the information of the fill level as a voltage value from 0-10 V. By means of this system, additional equipment such as an EIB module can be regulated.

3. Optional pressure sensor

Using a pressure sensor, alternative mediums or depths may be adapted to the use of the device. The sensor must be matched the required specifications of the device.

4. Optional drain pump

If the fill level of the tank reaches a specified value, then a valve or a pump can be activated. This is to prevent the fill level of the tank from exceeding a specified maximum level.

5. Optional refill

If the fill level in the main tank sinks below a specified level, then a second tank is employed to back up and refill the main tank. The pump used in this process must also be equipped with a mechanism to prevent it from running dry.

If this system is required, then the device must be sent to the manufacturer. There follows an additional calculation.

Note:

The standard system control device may be equipped with a maximum of three additional switch output point.

7. General installation and assembly regulations:

It is necessary to these instructions when installing a rain water usage equipment:

EN 806:

- Drinking water installation
- Planning and implementation
- Calculation of the pipe diameters
- Using the equipment

EN 1717:

- free outlet between drinking and rainwater
- Notification sign to inform that a rainwater usage system is installed in the locality
- Notification signs marking the rainwater outlets
- Notification signs marking the rainwater installations network
- Backflow prevention (e.g. a non-return/check valve)
- Frost free installation
- Reservoir/tank with air bleeding/ventilation
- No diameter reduction in the drainage system according to EN 1256
- Technical regulations in relation to groundwater drainage according to EN 752
- Drainage systems outside of buildings according to the regulations of the local services authorities
- *When required: Obligatory registration of the system and other mandatory stipulations*

Attachment A – Symbols used:



Attention! Pull out the mains plug from the socket before opening the device.



Warning of dangerous electrical voltage



Attention! An error has occurred.



Mains drinking water operation



Page down



Page up



Pump connection

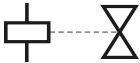

Valve connection



Main connection for data lead



Protection classification I



Only for use in a dry areas.

Room for your notes:

Purchase date :

Device serial number / Type : AS AQ

Active measuring length :

Software level AQ+ REV :

Design and specifications are subject to change without notice

Dated: April 2010 ; Version: AQ+ 2.2d

(Sprache: Englisch)